



St. Helens  
Council

# Bereavement Services Cemetery and Crematorium Management Rules

April 2005 - Reviewed March 2015



*Provisions of the Local Authorities Cemeteries Order 1977  
(as amended) and conditions made under this Order for the  
proper management, regulation and control of:*

## **St.Helens Cemetery and Crematorium and Newton-le-Willows Cemetery**

These Regulations have been written in plain language and the use of legal phrases has been avoided wherever possible.

These Regulations shall be used by the Council carefully and with due compassion. If you are not clear on any point please contact a member of the Bereavement Services staff either by personal visit, telephone or email as listed below:

The Bereavement Services Team are willing to assist you - particularly if this will avoid any unnecessary distress

St.Helens Cemetery & Crematorium Office  
Rainford Road  
St.Helens  
WA10 6DF

Tel: **01744 677406/407**

Fax: **01744 677411**

Email: **[sthelenscemetery@sthelens.gov.uk](mailto:sthelenscemetery@sthelens.gov.uk)** or  
**[sthelenscrematorium@sthelens.gov.uk](mailto:sthelenscrematorium@sthelens.gov.uk)**

# Contents

<b>Section</b>	<b>Page No.</b>
1. Explanation of some of the words used in the Regulations	1-2
2. Fees and Charges	2
3. Admission into Cemeteries	3-4
4. Office Opening Hours	4
5. St.Helens & Newton Chapel of Remembrance - Book of Remembrance Viewing Times.	5
Memorial Gardens Opening Times	5
6. Times of Burials and Cremations	6
Family Arranged Funerals	7
7. Grave Spaces	8
Selection and Ownership of Graves	8-9
Construction of Vaulted Graves	9-10
8. Burial Documentation	11
Notice of Interment (Burial)	11-13
Grave Deeds	13-14
Disposal Certificate	14
Completion of Statutory Declaration Form	14-15
9. Interment of Foetal Remains or Human Tissue	16
10. Burials and Burial Services	17-18
11. Burial of Casket of Cremated Remains or Pouring in a Private Grave	19-20
Public Graves	20
12. Purchasing a Grave Space	21
Lawned Grave Space Maintenance	21-22
Cemetery Extension (Sections 78-90)	23
Children's Section (Section 90)	23
Cremation Columbarium Niches	23
Traditional Family Graves (Section 89)	24
Traditional Section - Single Graves	24
- Family Graves	25

Cremated Remains Graves (Section 78/79) without extended Gardens	26
Unauthorised Memorials	27
Grave Deeds/Transferring Rights to Purchased Graves	27-28
Statutory Declaration to claim Grave Ownership	28
Relinquishing Rights to a purchased Grave	29
Change of Address	29
Preparing a Grave for Burial	29-30
After Care of Grave	30
Exhumations	30-31
13. Memorials - Erecting, Ownership and Responsibility to Maintain	31-32
Erection of Memorials on Lawn-Type Graves	32
Specification for Erecting Memorials	32-33
Application to Erect a Memorial	33-35
Dimensions and Specifications	35-37
Memorial Stability (as NAMM Code of Working Practice)	37-40
Work Permits	40-42
Memorial Insurance	42
14. Temporary Grave Markers	43-44
15. Maintenance and Care of Graves and Memorials	45-47
16. Cremated Remains Graves	48-50
17. Cremation Documentation	51-52
Stillborn Cremations	
Cremation of a Foetus	
Cremation of Human Tissue	
18. Construction of Coffins used for Cremation	53-55
19. Services in the Crematorium Chapel	56-57
20. Cremation Process	58
21. Final Disposal of Cremated Remains (Ashes)	59-61
22. Floral Tributes left at the Crematorium	62
23. Floral Tributes left in the Gardens of Remembrance	63
24. Floral Tributes - Christmas and other Religious Festivals	64

25	Books of Remembrance	65
26.	Memorialisation	66
27.	General conditions which apply to all persons visiting the Cemeteries:	
	Dogs	67
	Vehicle Users and Horse-Drawn Hearses	67
	Visitors	67-69
	Use of Cameras	69-70
	Gratuities	70
28.	Removal and Prohibition from a Cemetery	71
29.	Religions, Beliefs and Faiths	71
30.	Local Authorities Cemeteries Order 1977 (LACO)	72-73
31.	Fines and Penalties	74
32.	Extent of Regulations	74

## 1.0 Explanation of some of the words used in the Regulations

1.1 When used in these Regulations, the following words have the attached meanings:-

**“The Council”** means The St.Helens Council.

**“The Cemetery”** means St.Helens or Newton-le-Willows Cemetery.

**“The Crematorium Chapel”** or **“Chapel”** means St.Helens Crematorium Chapel or the Burial Chapel at Newton-le-Willows Cemetery.

**“The Cemetery and Crematorium Office”** means the office, which is located at the exit side of the St.Helens Crematorium building.

**“Private Grave”** means a vault; walled grave or lawned-type grave space where the sole right of burial in that grave may be purchased.

**“Cremated Remains”** means ashes and vice versa.

**“Cremated Remains Grave”** means the graves at St.Helens and Newton-le-Willows Cemeteries for the interment of cremated remains only.

**“Grave Owner”** means a person purchasing the sole right of burial in a private grave, which is written on the grave deed.

**“Public Grave”** means a grave space, which cannot be separately purchased and is owned by St.Helens Council.

**“Coffin”** means any rectangular casket, cardboard coffin, wicker basket coffin or traditional coffin.

**“Memorial”** means any stone, cross, vase or monument or any other commemoration.

**“Interment”** means burial and vice versa.

**“Funeral”** means both burial and cremation.

**“Funeral Director”** means any person who organises a funeral, and acts as the agent for the bereaved family.

**“Bereavement Services Manager”** means the Council’s Bereavement Services Manager or any other Officer of the Council who has been asked by the Director of the Environmental Protection to carry out the duties of the Bereavement Services Manager.

**“Clear Working Days”** means excluding the day the request is made or submitted, followed by the number of days counting only when the Cemetery and Crematorium Office is open for business. The event then can occur on the next working day (or later).

**“External size of coffin”** means the widest and longest external dimension of the coffin, including the coffin lid and all fittings and handles.

**“NAMM”** means the National Association of Memorial Masons.

**“BRAMM”** means the British Register of Accredited Monumental Masons.

## **2.0 Fees and Charges**

- 2.1 The fees and charges that the Council makes for the various burial, cremation and memorial services are listed in tables. These are available from the Cemetery and Crematorium Office.
- 2.2 The fees are reviewed annually and run from 1st April to 31st March each year.
- 2.3 The Bereavement Services Manager is authorised to agree fees for matters not included in the tables, subject to consultation with the Director of Environmental Protection.
- 2.4 Fees for any service must be paid in advance. No credit facilities are given or offered. The Bereavement Services Manager has the right to ask for payment at the time of the booking.

### 3.0 Admission into Cemeteries

The cemeteries will be open to the public on each day of the year as follows:

- 3.1 Only Blue Badge holders will be permitted vehicular entry into the Cemetery grounds via the automated bollard entry system, however they must contact the Cemetery Office to obtain a permit. Other vehicles must use the car park and vehicles permitted entry must keep to the main carriageways, follow the traffic management system in place and adhere to all speed restrictions. Drivers must not park on grass verges or grave plots. Permits are available from the Cemetery and Crematorium Office to allow this vehicular access to the cemetery.

Hours of operation for vehicular entry into Cemetery:

#### **Monday to Sunday (including Bank Holidays)**

November to February	9.00am to 4.00pm
March to April	9.00am to 5.00pm
May to August	9.00am to 7.00pm
September to October	9.00am to 5.00pm

- 3.2 Any Cemetery visitor applying for a permit to enter the Cemetery via the vehicular entry system must agree to the following terms and conditions at the time of issue and renewal:

- to follow the St.Helens Cemetery and Crematorium Management Rules and keep within the 5mph speed limit at all times.
- to give pedestrians priority and be considerate of others when parking.
- to drive respectfully at all times with due care and attention to all Cemetery visitors and staff.
- to surrender the car permit upon request by the Bereavement Services Manager and accept that the car permit may be withdrawn in the event of failure to comply with the St.Helens Council Cemetery and



Crematorium Management Rules, including the speed limit and parking restrictions.

- to surrender their car permit in the event of their Blue Badge being revoked and agree not to allow any other person to use their permit in their absence. Spot checks may take place and the appropriate action taken if it is noted that the permit holder is not in attendance, the permit could be withdrawn from use.
- After the initial permit is issued any misplaced or lost permit that needs replacing, a fee will be charged for replacement.
- The blue badge holder will need to re-register their blue badge reference number with the Cemetery Office each time this expires, so that they can continue to access the Cemetery by vehicular access.

3.3 The Cemeteries are accessible to pedestrian entry daily, at weekends and evenings.

Children under 16 years visiting the cemetery must be supervised by an adult.

Children are not permitted to enter the cemetery outside the times stipulated above.

## **4.0 Office Opening Hours**

4.1. The Cemetery and Crematorium Office is open for the booking of funerals and for dealing with all other matters in connection with the Council's Burial and Cremation Services at the following times:

**Monday to Friday** 9.00am to 12.30pm and  
1.30pm to 4.30pm

**Saturday and Sunday** Closed

4.2. The office is also closed on all Public and Bank Holidays including Christmas Day, Boxing Day, New Year's Day, Good Friday, Easter Monday, May Bank Holiday, Spring Bank Holiday Monday, and Summer Bank Holiday Monday.

## **5.0 St.Helens & Newton Chapel of Remembrance - Book of Remembrance Viewing Times. Memorial Gardens Opening Times**

- 5.1. The Chapel of Remembrance at St.Helens Cemetery is open for viewing the Book of Remembrance as follows:

### **Monday to Friday**

November to February	9.00am to 4.00pm
March to April	9.00am to 5.00pm
May to August	9.00am to 7.00pm
September to October	9.00am to 5.00pm

### **Saturdays, Sundays and Bank Holidays**

Open from 10.00am

## **MEMORIAL GARDENS OF REMEMBRANCE**

The Memorial Garden of Remembrance is open the same times as listed above.

- 5.2 Newton-le-Willows Chapel - Book of Remembrance viewing times:  
Open daily between the hours of 10.00am to 4.00pm
- 5.3 All visitors are requested to observe and be respectful if funeral services are taking place during these times.

## **6.0 Times of Burials and Cremations**

- 6.0.1 Neither burials nor cremations are able to take place on the following days:- Christmas Day, Boxing Day, New Year's Day, Good Friday, Easter Monday, May Bank Holiday, Spring Bank Holiday Monday, Summer Bank Holiday Monday or any other public holiday.
- 6.0.2 It is important that funerals do not arrive at the Cemetery or Crematorium late and it is equally important that they leave on time. Where late arrival or departure causes interference of one funeral with another or incurs the Council in added costs, then an additional fee may be recharged to the Funeral Director or person officiating at the funeral service.
- 6.0.3 If the arrival time of a funeral is so late that it will seriously affect other funerals or because of the lateness of the time of day or because of any other difficulties, then the Bereavement Services Manager may postpone the funeral to some other available or convenient time.

### **6.1 Burials**

- 6.1.1 Burials may take place at such times as may be agreed with the Bereavement Services Manager, between the following hours, allowing 30 minutes between funerals:
- |                    |                  |
|--------------------|------------------|
| Monday to Thursday | 9.00am to 3.15pm |
| Friday             | 9.00am to 2.15pm |
- 6.1.2 Saturday and Sunday burials only by arrangement with the Bereavement Services Manager. If sufficient members of staff are available to provide the service, an additional fee is charged for this request.
- 6.1.3 Burials shall be arranged and booked at 30-minute intervals.
- 6.1.4 The Funeral Director must show respect for any other funeral that may be taking place within the cemetery.
- 6.1.5 If a family request bagpipes or similar instruments to be played or if any funeral would cause upset to other mourners, then prior arrangements with the office must be made as soon as possible to eliminate any complaints from other bereaved families.

## **6.2 Cremations**

6.2.1 Cremations may take place at such times as may be agreed with the Bereavement Services Manager, between the following hours at 30-minute intervals:

Monday to Friday 9.00am to 4.00pm

6.2.2 Saturday morning cremations may be arranged with the Bereavement Services Manager, if sufficient members of staff are available to provide the service. An additional fee is charged for this request.

6.2.3 Cremation times are booked at 1/2 hourly intervals. This allows 5 minutes to seat the mourners, 20 minutes for the service and 5 minutes to escort the mourners from the chapel. If more time is required for the service, then an additional 1/2 hour time should be booked. This is certainly encouraged where more than 3 pieces of music and special requests are made to ensure the bereaved family do not feel rushed and restricted. This will incur an additional charge for the use of the chapel.

## **6.3 Family Arranged Funerals**

6.3.1 Bereaved families have the right to make funeral arrangements directly with the Cemetery and Crematorium Office.

6.3.2 Bereavement Services staff are not responsible for making all the necessary arrangements but will offer advice and assistance in making the correct arrangements in compliance with the Cemetery and Crematorium Management Rules.

## 7.0 Grave Spaces

### 7.1 Selection and Ownership of Graves

- 7.1.1 All interments (burials) must be carried out in either a private grave or in a public grave. Cremated remains (ashes) can only be buried in private graves.
- 7.1.2 A plan which shows which graves have been purchased and which graves are still available for burials is kept at the Cemetery and Crematorium Office, and this may be inspected free of charge.
- 7.1.3 The plan also shows the various sections of the Cemeteries. Graves are available for one, two or three burials depending upon their location and ground conditions and designated areas of the Cemetery are set aside for the interment of cremated remains for either up to four cremation caskets or six cremation caskets dependent on the location selected. The depth of the requested grave **must** be stated at the time that the grave is purchased by the Funeral Director, or in the absence of him, the family who are wishing to purchase the grave.
- 7.1.4 Any person over the age of eighteen may purchase the Exclusive Right to have burials in any private grave for a period of fifty years. This period can be extended after the term, and the grave owner will be notified by the Bereavement Services Manager upon the expiry of the fifty years. The Rights cannot be extended until after the expiry of the lease. If the grave owner has passed away after this time, then the extension can be applied for by the nearest surviving relative of the grave owner provided that the correct assignment of ownership is carried out in line with the burial authorities recommendations and the appropriate fee paid at the time of the application being made.
- 7.1.5 Before a purchased grave space is opened for burial, the grave deed must be produced to the cemetery and crematorium office as proof that the appropriate person has authorised the burial to proceed. However, if this is not available, then the grave owner should sign the necessary

documentation required by the burial authority in order for the burial to proceed. A fee will be charged for this documentation.

- 7.1.6 The fee for the Exclusive Right to Bury must be paid at the time that the arrangements are made at the office, and a Grave Deed will be issued to the Grave Owner or Funeral Director soon after.
- 7.1.7 The Deed will confirm the number of burials permitted within the grave. The Deed does not mean that the grave owner owns the land, he owns the Right to Bury only for the fifty-year term. The land always belongs to the Council.
- 7.1.8 When a grave is purchased to accept a given number of interments, should circumstances beyond the control of the Council prevent the number of interments required being possible, the Council shall not be held liable in any way.
- 7.1.9 A separate application is required to erect a memorial. For further guidance refer to section 13 Memorials - Erecting, ownership and responsibility to maintain.

## **7.2 Construction of Vaulted Graves**

- 7.2.1 The burial authority may grant a grave owner the right to construct a burial chamber within the grave space. The materials and construction of a vault or burial chamber must be specified and agreed by the burial authority.
- 7.2.2 An application must be submitted by the grave owner via the building contractor, who must also be approved by the burial authority. The application must show details of the dimensions and the construction methods.
- 7.2.3 The application must be made by the registered grave owner, who may request that the burial authority organises the work to be undertaken. The burial authority will re-charge all costs for this work to the grave owner.
- 7.2.4 The preparation and excavation of the grave must be undertaken by the authority's own staff. Any additional costs incurred will be recharged to the grave owner.

- 7.2.5 The request to carry out this work will be refused where the work would interfere or disrupt an adjacent grave space.
- 7.2.6 The location of any new grave where a request for vaulting is made will be determined by the Bereavement Services Manager. Please refer to Section 12.9 for types of graves available.
- 7.2.7 Where the final burial is vaulted to comply with legislation concerning the minimum depth of soil on any final coffin, no further Cremated Remains interments will be permitted to take place and the grave space will be marked closed following the vaulted burial.

## 8.0 Burial Documentation

8.1 Before the interment (burial) or interment/pouring of cremated remains of a deceased person can take place, the Bereavement Services Manager must have received from the Funeral Director or the person who is making the arrangements:

- (i) The confirmatory Notice of Interment duly signed by the grave owner and the Funeral Director, together with the correct fees.
- (ii) The Grave Deeds.
- (iii) An appropriately completed Statutory Declaration, where necessary.
- (iv) The Disposal Certificate or Coroner's Order for Burial.

### 8.2 **Notice of Interment (Burial)** - available from the 'Cemetery and Crematorium Office'

8.2.1 Notice is required so that the grave can be prepared for burial. Forms of Notice, which contain all the details which the Council requires, must be delivered to the "Cemetery and Crematorium Office" as soon as possible after the initial telephone booking. The burial will not be processed until the form has been delivered.

The following minimum notice for receipt of paperwork is required:

- (a) For burial in a private or public grave - 3 clear working days' notice.
- (b) For burial in an existing vault or walled grave - 3 clear working days' notice.
- (c) For burial or pouring of cremated remains in a private grave - 2 clear working days' notice.
- (d) For a burial in a new vault or walled grave - by arrangement with the Bereavement Services Manager.



- 8.2.2 The burial will not be accepted or processed without:
- written confirmation of the date and time of the burial,
  - the name of the deceased,
  - the location of an existing grave,
  - the family requirements or expectations on future use of the grave,
  - the external size of the coffin or casket,
  - or for a new grave, the depth of the grave required.

Failure to comply with this request will lead to the burial being postponed.

8.2.3 If it is not possible to carry out the work required to prepare the grave within the above times because of practical difficulties in the cemetery, then the Manager is at liberty to extend the required notice.

8.2.4 A burial will be accepted at short notice if all the documentation is produced with immediate effect and if it is possible to facilitate the request, bearing in mind the existing workload.

8.2.5 It is preferable for notices to be hand-delivered to the Cemetery and Crematorium Office because any mistakes can be corrected at that time. Notices can be sent by post if accompanied by the proper fees, but if notice is given by this method and a mistake occurs which results in the funeral being delayed, then the Council cannot be held responsible.

8.2.6 The start of the required notice is the time when the cemetery **receives** the request, including the essential information (see 8.2.1).

8.2.7 A preliminary notice of the intention to carry out a burial may be given by telephone, but this must be properly confirmed by way of the proper Notice of Interment as soon as possible. If notice is given by this method and a mistake occurs which results in the funeral being delayed, then the

Council cannot be held responsible. A copy of the documents may be sent to the cemetery and crematorium office, by an agreed means, giving full confirmation of the details, which the “Cemetery and Crematorium Office” may act upon, but the original forms must be submitted before the date of the interment.

8.2.8 The interment notice must be signed by the registered grave owner to authorise the burial to proceed, and the declaration on the reverse of the form must also be signed to acknowledge the extract of the regulations relating to the prohibition of kerbs, fences, ornaments and other unauthorised memorials on graves. The application will not be processed without all signatures being made.

8.2.9 Individual coffins and cremated remains caskets must be delivered to the cemetery or crematorium for the burial or cremation service.

The only exception is where baby twins are to be buried or cremated together in one coffin or where a mother and baby are to be buried or cremated.

The Bereavement Services Manager will determine the age of the child to which this rule applies.

8.2.10 The family or Funeral Director **must** make the relevant officer aware if the deceased person died of a **notifiable disease**. Provisions will have to be made with the staff concerned and the Bereavement Services Manager, along with the Environmental Protection Department, who are at liberty to make any such decision about the disposal of the deceased for the wellbeing of all staff and the appointed Funeral Director’s staff.

### **8.3 Grave Deeds**

8.3.1 Where the burial is to take place in a private grave for which ‘Grave Deeds’ have already been issued by the Council, then these must be sent or taken to the Cemetery and Crematorium Office along with the above ‘Notice of Interment’.

If the ‘Grave Deeds’ have been lost or misplaced by the grave owner, then it is necessary for a declaration to be

signed at the Cemetery and Crematorium Office so that the burial can go ahead. In certain circumstances, the grave owner may be asked to sign a Statutory Declaration Form, this must be verified and signed by a Commissioner for Oaths or a Magistrate.

The original paperwork and signed declaration, if a copy has previously been sent, then the original must be delivered to the Cemetery and Crematorium office, at least one clear day before the date of the interment.

## **8.4 Disposal Certificate**

8.4.1 This is the Green Disposal Certificate issued by the Registrar of Births and Deaths, or if the Coroner opens an inquest on the deceased then he will issue a white Coroner's Order for Burial. If a deceased person has passed away abroad (i.e. out of England and Wales), a Certificate of No Liability to Register is issued by the Registrar of Births and Deaths for where the burial is to take place. The appropriate certificate must be produced at least one clear day before the date of the interment.

8.4.2 In the case of a stillborn child, the certificate of the Registrar of Births and Deaths or an Order off the Coroner will be required. These documents must also be delivered to provide at least one clear day's notice.

## **8.5 Completion of Statutory Declaration Form**

8.5.1 Where the grave owner is deceased, and the original grave owner's estate went to probate or letters of administration, the person/s entitled under these documents to the grave owner's estate are the rightful person/s to make the claim of ownership, so that the burial can proceed. The original documents must be produced to the Bereavement Services Manager so that the records can be amended accordingly.

8.5.2 If the original grave owner is deceased and their estate did not go to probate or letters of administration, then it will be necessary for the rightful person/s to complete a 'Statutory Declaration' form at the Cemetery and Crematorium Office,

based upon each individual family's circumstances. This form will then need to be taken to a Commissioner for Oaths or Magistrate for final verification and signatures (they may make a charge for this service). Once this is completed, it should be forwarded immediately to the Cemetery and Crematorium Office prior to the grave space being opened; a fee will be charged for the transfer of ownership.

- 8.5.3 For reference and guidance concerning ownership, please refer to the St.Helens Council leaflet 'Grave ownership' available from the Bereavement Service.

## **9.0 Interment of Foetal Remains or Human Tissue**

- 9.1 In the case of interment of foetal remains or human tissue, although the legal documentation is different in these cases, the interments will be carried out reverently. The same Notice of Interment details are required, along with the grave deed production or signature on the Indemnity form or Statutory Declaration. A letter of confirmation from the hospital is also required. The documents must be delivered in the same way as described in Section 8, and the same notice period will apply.
- 9.2 The burial of human tissue will only be allowed to take place in a private grave space.
- 9.3 The position and location of such burials will be decided by the Bereavement Services Manager at the time of the booking.
- 9.4 A fee will be charged for these types of burial.

## 10.0 Burials and Burial Services

- 10.1 Only wooden, cardboard and wicker coffins can be used for burials. A nameplate for identification purposes must be fixed to each coffin. Burials without coffins are strictly forbidden.
- 10.2 Coffins must be fully lined to prevent any seepage from within the coffin and all coffin joints must be sealed. The use of metal lining is forbidden. The coffin must be fitted with a minimum of four standard handles and coffin end rings, for assisting with lowering into the grave. The coffin lid must be secured before delivering to the cemetery.
- 10.3 Due to Health and Safety implications, only Bereavement Services staff are permitted to dig graves, but backfilling may be allowed by permission of the Bereavement Services Manager, and under full staff supervision. Health and Safety instructions and Risk Assessments must be complied with at all times.
- 10.4 The Sexton is responsible for identifying the best route to the graveside, bearing in mind the narrow paths and paying due attention to surrounding graves and Memorialisation.
- 10.5 The Funeral Director is responsible for arranging for any coffin or casket to be placed in position on the top boarding of a grave and is also responsible for lowering the coffin into the grave. It is the responsibility of the Funeral Director to bring sufficient staff to carry out this task, the Cemetery Supervisor will also assist in this process.
- 10.6 Religious services or ceremonies may be held at the graveside provided that they are conducted reverently. These should not take longer than 20 minutes unless the timing is specifically agreed with the Bereavement Services Manager.
- 10.7 Religious services or ceremonies prior to burial may be carried out in the **Crematorium Chapel at St.Helens or the Burial Chapel at Newton-le-Willows Cemetery**, for which a separate charge will be made. The Conditions

listed in Section 19, paragraphs 19.2 to 19.5, will apply to these services, except that the coffin **may** either be placed on the chapel catafalque or can be retained on its bier (carriage) in front of the catafalque whilst the service takes place.

- 10.8 It may be necessary to remove headstones or items on adjacent graves to allow a grave to be prepared. Where possible, the Cemetery and Crematorium Office will contact the grave owner to inform them of the necessity to carry out this work.

## **11.0 Burial of Casket of Cremated Remains or Pouring in a Private Grave**

- 11.1 Cremated remains may be either buried in a casket or poured loosely into a grave.
- 11.2 An appointment must be booked via the Cemetery and Crematorium Office, whether relatives wish to be present at the ceremony or not, and 2 days' notice is required.
- 11.3 The times of the appointments are the same as Regulation 6.1.
- 11.4 A Notice of Interment is required, whether the cremated remains are buried or poured, along with the Grave Deeds if it is an existing grave (or the Indemnity form or Statutory Declaration must be signed/completed accordingly), and the Cremated Remains Certificate which is issued by the cremation authority must also be submitted to the Cemetery and Crematorium Office along with the appropriate fee, before the appointment is due to take place.
- 11.5 If the cremated remains are to be buried in a casket, the casket should be wooden which will facilitate decay. Only biodegradable materials may be used in the construction of the casket. If the cremated remains are to be poured into the grave, a container must be provided for this purpose, which will be returned after the ashes have been poured into the grave.
- 11.6 Where the grave owner chooses to pour any cremated remains loosely into the grave, it will not be possible to open the grave thereafter for an interment of a full-size coffin, as the process would disturb the poured remains.  
  
Therefore, pouring should only take place when the grave is either full, or where it is not intended to use the grave in the future for additional interments, a signed form of declaration (copies available from the Cemetery and Crematorium Office) should be made and forwarded to the Cemetery and Crematorium Office prior to the burial ceremony. Caskets of cremated remains may be interred



after cremated remains have been poured, as the location of the poured remains are recorded, and disturbance can be avoided when preparing for the interment of a casket of cremated remains.

## **11.7 Public Graves**

- 11.7.1 Public or 'common' graves are available at each cemetery and a fee is paid for burial within.
- 11.7.2 Public graves may only be used to inter any person who either died in St.Helens or who resided in St.Helens at the time of death.
- 11.7.3 Public graves may be used when a deceased person has no known relatives or funding to pay for a private burial.
- 11.7.4 The Council may open a grave at its discretion on the relevant burial plot, and more than one person will be buried within the grave.
- 11.7.5 No memorial is allowed to be erected onto any public grave.
- 11.7.6 Cremated remains cannot be buried in public graves.

## 12.0 Purchasing a Grave Space Lawned Graves - Maintenance

12.1 Pre-purchase of graves shall be limited to one grave per purchaser, in advance of burial.

If a burial is to take place within a new grave, and the pre-purchase of an adjacent grave is requested, only one grave will be permitted to be purchased.

The Council reserves the right to refuse any pre-purchase of a grave, at its sole discretion.

12.2 It is the policy of the Council that all new graves are of the lawn type, where the headstone is placed on a foundation at the head of the grave and the main part of the grave is in the form of a level grass lawn. Therefore, **kerbstones, chippings, pebbles, statues, windmills, toys, plastic trees** and any other style of ornamentation **are not allowed** to be erected or placed upon or around the graves.

12.3 If the owner of the grave wishes to plant a small garden at the head of the grave, then this is allowed, as long as the garden area does not exceed 12 inches from the headstone into the grave, nor does it exceed 36 inches in width (300mm x 900mm wide). This area must not be enclosed with small kerb edgings of any description, and only small plants that will not reach a height greater than 18 inches (450mm) on maturity shall be planted in this area.

12.4 Nothing must be placed on the lawned area of a grave and it is not permitted for any grave owner to do anything else which will interfere with or distract lawn maintenance by the Council. If any shrubs or other plants which have been planted by grave owners become so overgrown that they impede the ground maintenance programme or look unsightly or unkempt, then the Bereavement Services Manager may remove them without prior notification.

12.5 The grave must not be mounded with soil or planted with bulbs or perennials.

- 12.6 As time goes by, the surface of the grave will settle down and drop, making mowing more difficult, so from time to time the Council will, at its discretion, add soil to the grave and surrounding area to bring it back to a proper level. This is done without any cost to the grave owner.
- 12.7 The maintenance of the garden area and any memorial on the grave is the responsibility of the grave owner. It is the responsibility of the grave owner to keep the Cemetery and Crematorium Office informed of any change of address for contact purposes, should the need arise to contact them.
- 12.8 Where grave owners would like to personalise their grave and extend the garden area, the Bereavement Services Manager will allow families to create a garden area which must not exceed 3 feet in width by 24 inches in depth (900mm x 600mm). This garden area may also be adorned with kerb edgings, foot kerbs, statues, ornaments, vases or any other form of Memorialisation, at a request to the Cemetery Office. The edgings must not exceed 12 inches (300mm) in height.

**All Grave Owners** who wish to **extend and adorn their grave must seek permission** from the Bereavement Services Manager and **must sign a declaration of Extended Garden application form** available from the Cemetery and Crematorium Office to agree to abide by the regulations and ensure that the areas of grass where the mowing machinery cannot access because of this form of adornment is cut and maintained to the same standard as the adjacent graves.

The Bereavement Services Manager retains the right to remove any such item from a garden area which is not suitable for display.

Failure to comply with these regulations will lead to the Bereavement Services Staff removing any such item from the grave area without any prior approval of the grave owner. All grave owners must comply with the St. Helens Council's Cemetery and Crematorium Rules and Regulations.

## **12.9 Cemetery Extension (Sections 78 to 90)**

12.10 The Cemetery was extended in April 2011 to provide extra burial space and to enable increased choice for the bereaved in selecting a final resting place for their loved ones. The majority of sections are traditional lawned sections but there is now the opportunity for the following grave and memorial types.

### **12.11 Children's Section (Section 90)**

An exclusive Children's burial section is available to provide individual Children and Infants graves.

A lease will be granted for a period of 50 years.

A separate application will be required for the right to erect a memorial.

The size of each grave space is 1220mm x 1500mm. Individual Memorials are permitted to be erected on each grave to a height of 33 inches/840mm, breakdown as follows;

Plate height 27 inches (686mm) Width 21 inches (533mm)  
Thickness 3 inches (75mm)

Base width 24 inches (610mm) Depth 12 inches (300mm)  
Thickness 3 inches (75mm)

Terrazzo/sub-base Width 26 inches (660mm) Depth 14 inches (355mm) Thickness 3 inches (75mm)

Please refer to Section 13.0 Memorials - erecting, ownership and responsibility to maintain.

The Extended Garden Scheme where grave owners can personalise their grave does apply to this Section please refer to Section 12.8.

### **12.12 Cremation Columbarium Niches**

The central part of the Cemetery Extension design incorporates Columbarium niches (sanctum 12/2000) where two sets of cremated remains can be placed securely behind an inscribed tablet on a lease period of either 10 or 20 years. At the end of the lease period the lease can be renewed or the cremated remains removed to a location of choice by the owner of the niche.

### 12.13 Traditional Family Graves (Section 89)

Section 89 within the Cemetery Extension has been set aside for traditional family graves and vaulted graves as an alternative to earth burials.

This area of the Cemetery is a single row, where families can construct either a single grave or a family vaulted grave consisting of one, two or three grave spaces with an option of construction of an underground vault. The size of the vault will be no larger than the grave space and will include for a specific number of interments.

A separate application will be required for the right to erect a memorial. Please refer to section 13 erecting, ownership and responsibility to maintain.

### 12.14 Traditional section - single graves

The size of each individual grave space is 2.74m (9 feet) by 1.21m (4 feet) in addition to the strip of virgin ground 450mm (18 inches) wide. This is however dependant on the space available in the chosen location and the type and specification of any required vault.

A full kerb set memorial will be allowed and must not exceed the dimensions of the grave space. The memorial must not exceed 1.5m (4 foot 11 inches) in height or 900mm (3 feet) in width.

#### Single Grave footprint size of Memorial and Kerb surrounds

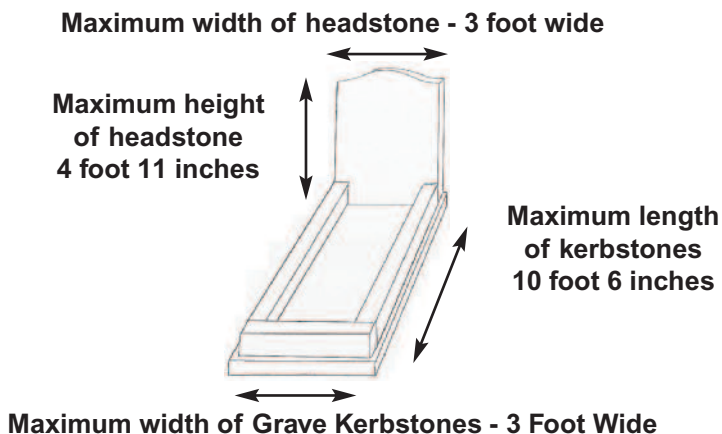

## 12.15 Traditional section - Family graves

A family grave will consist of two or three adjoining grave spaces. The size of a family plot will be based on the combined size of the number of individual grave spaces.

The maximum height of a headstone that will be permitted is 2.286m (7 feet 6 inches) over three adjoining graves.

The maximum height of a headstone that will be permitted over two graves is 1.8288m (6 feet).

A full kerb set and headstone must not exceed the dimension of the grave space and additional virgin ground and must not restrict access to adjoining graves.

### Family Double Grave footprint size of Memorial and Kerb surrounds

**Maximum width of headstone - 6 foot wide**

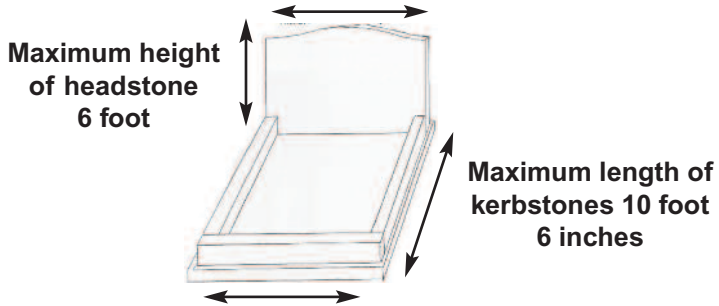

**Maximum width of Grave Kerbstones - 6 Foot Wide**

### Family Grave over three graves footprint size of Memorial and Kerb surrounds

**Maximum width of headstone - 9 foot wide**

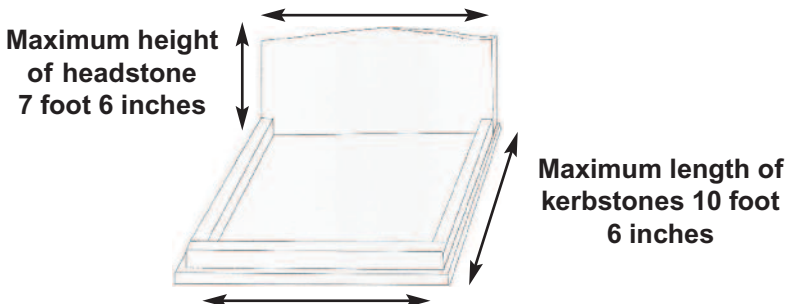

**Maximum width of Grave Kerbstones - 10 Foot Wide**

## **12.16 Cremated Remains Graves (Section 78/79) without Extended Garden**

An area within the Cemetery Extension has been set aside for the interment of Cremated Remains, each grave space can accommodate up to four caskets of Cremated Remains. A lease will be granted for a period of fifty years. A separate application will be required for the right to erect a memorial.

The size of each grave space is 1220mm x 1500mm. Individual Memorials are permitted to be erected on each grave to a height of 33 inches/840mm, breakdown as follows;

Plate height 27 inches (686mm) Width 21 inches (533mm)  
Thickness 3 inches (75mm)

Base width 24 inches (610mm) Depth 12 inches (300mm)  
Thickness 3 inches (75mm)

Terrazzo/sub-base Width 26 inches (660mm) Depth 14 inches (355mm) Thickness 3 inches (75mm)

Please refer to Section 13.0 Memorials - erecting, ownership and responsibility to maintain

Within these Sections nothing will be permitted on the grave space other than within the 10 inch border which will be planted out with small plants and a bark topping by the Council. No extended garden will be permitted on this Section of the Cemetery. Only flower flutes are permitted to be placed in front of the memorial in the planted border. If grave owners wish to plant their own seasonal choice of plants within this area they must notify the Bereavement Services Manager of their intention, these plants must be maintained and kept in a good condition by the grave owner.

Any plants not maintained by the grave owner will be removed by the Council with no prior notice given to the grave owner.

## **12.17 Unauthorised Memorials**

- 12.17.1 Any item placed on any grave or vault without the prior consent of the Bereavement Services Manager is an unauthorised memorial.
- 12.17.2 Where such an item would, on application to the Bereavement Services Manager, be accepted as a temporary or permanent memorial, the owner shall be invited to apply formally for permission to place the item on the grave.
- 12.17.3 Where such an item fails to be accepted as a temporary or permanent memorial, two weeks' notice will be given to the grave owner, where possible, to remove the unauthorised memorial.
- 12.17.4 When a grave owner cannot be traced or when the served notice expires and the owner fails to comply with the notice, the Bereavement Services Manager may at this time remove the unauthorised memorial.
- 12.17.5 An unauthorised memorial when removed will be retained by the Bereavement Services Manager for collection by the grave owner.
- 12.17.6 Where an owner fails to collect an unauthorised memorial after six months, taken from the date of its removal the Bereavement Services Manager may dispose of the unauthorised memorial.
- 12.17.7 Failure by the Bereavement Services Manager to give notice to the owner to remove an unauthorised memorial shall not cause the item to become a temporary or permanent memorial.
- 12.17.8 The unauthorised memorial may be removed any time after the expiry of the period of notice, which has been served on the owner.

## **12.18 Grave Deeds**

- 12.18.1 Grave Deeds will be issued to any new grave owner, or returned to the existing owner or Funeral Director after the interment. The Deeds must be kept safe and produced any time the grave is to be opened for an interment or for a burial or pouring of cremated remains.



- 12.18.2 The monumental mason may ask the grave owner to produce the Deeds, when organising for memorial work to be undertaken (as proof of ownership).
- 12.18.3 The cemetery and crematorium office must be informed of any change of address or of the death and subsequent transfer of ownership. This information has to be recorded in the grave registers for future reference. At this time the Bereavement Services Manager may ask for a Statutory Declaration of Ownership to be completed.
- 12.18.4 The cemetery and crematorium office must be notified if the Deed becomes lost. A duplicate Deed will only be issued in exceptional circumstances at the discretion of the Bereavement Services Manager and a fee will be charged for the new Deed.

### **12.19 Transferring Rights to Purchased Grave/Statutory declaration to claim Grave Ownership.**

- 12.19.1 The exclusive Right of Burial may only be transferred to a relative by the Registered Grave Owner, unless the Council agrees otherwise, or unless the Right of Burial is transferred by way of a properly drawn up Will or letters of administration upon the death of the Owner. The appropriate documentation must be signed in the cemetery office upon the production of the Grave Deed by the grave owner. There is a charge for this transfer of ownership. When the grave owner is deceased, an appropriately completed Statutory Declaration Form will need to be completed, where necessary. For more guidance concerning the completion of a 'Statutory Declaration' refer to Section 8.3.1 and 8.5.
- 12.19.2 Any person claiming to have had a Right of Burial transferred to him or her must produce satisfactory evidence of this to the Bereavement Services Manager i.e. the production of a duly signed letter or a copy of the Will.
- 12.19.3 The Council will not act upon any transfers, which may have taken place without the notification or consent of the Council.

## **12.20 Relinquishing Rights to a Purchased Grave**

- 12.20.1 Where the Rights to burial have never been exercised (i.e. no interment has taken place), the grave owner may sell back the grave space to 'The Council' in return for the sum that was paid at the time of purchase.
- 12.20.2 The Grave Deed must be produced to the cemetery and crematorium office along with the receipt of sale and the relevant office document must be signed and completed by the grave owner.
- 12.20.3 There is no charge made for this relinquishment and the cheque for the amount will be reimbursed soon after the transaction.

## **12.21 Change of Address**

- 12.21.1 The registered grave owner must inform the cemetery and crematorium office of any change of address. This should be in the form of a letter, delivered to the cemetery and crematorium office, along with the Grave Deed so that the records can be updated. Failure to inform the office will lead to communication problems in the future between the grave owner and the office.

## **12.22 Preparing a Grave for Burial**

- 12.22.1 When an instruction is given to open a grave space for interment, it may be necessary to remove the headstone or memorial away from the grave during the preparation work. The memorial may be returned to its original place after the burial, once the ground has settled, which may take up to 20 weeks.
- 12.22.2 It may also be necessary to move any adjacent memorials to access the grave space. Where this is the case, the grave owner will be notified as soon as possible, if the grave registers have the correct contact details. The memorial will be re-positioned and secured after the burial has taken place.
- 12.22.3 It will be necessary to mound the excavated spoil onto an adjacent grave. The grass will be protected with wooden boards and any adjacent memorial will be covered for protection. If forbidden items such as kerbstones or vases

have been placed on the grave, then they will be removed to allow the grave to be prepared for the burial. These items will not be returned to the grave by the staff and the Bereavement Services Manager will contact the grave owner to inform him/her of the necessity to remove them. The grave owner will then be expected to remove the items from the cemetery. Every attempt will be made by the office to contact grave owners, but where this is not possible the items will be placed at the rear of the headstone or stored for safety and collection by the grave owner.

12.22.4 After the burial, the surrounding grassed areas will be cleared of soil, all divots levelled off using top soil and grass seed, where necessary and left as tidy as possible.

### **12.23 After Care of Grave**

12.23.1 After the interment, there will be a settlement period of the earth. This could take between 12 and 20 weeks. The cemetery staff will level off the graves during this period, and will apply seed or turf to the area when ready. Where memorials were moved to allow for the grave to be prepared, they can only be replaced when the ground is consolidated and firm, and this arrangement is the responsibility of the grave owner.

12.23.2 The floral tributes will be removed by the staff, when they have perished, which could be any time from 1-3 weeks after the interment, depending upon weather conditions, **unless an instruction is given by the grave owner to the office not to do this.**

12.23.3 Floral tributes left on any grave are left entirely at the risk of the grave owner and no liability for loss of, or damage to, any floral tribute can be accepted by the Council.

### **12.24 Exhumations**

12.24.1 Exhumations may be arranged in accordance with either a Ministry of Justice Licence or a Faculty from the Church of England Diocese.

12.24.2 The grave owner must make the application and the Bereavement Services staff will assist with the completion

of this paperwork.

- 12.24.3 Only Bereavement Services staff may carry out the exhumation, on receipt of relevant documentation.
- 12.24.4 The grave owner must bear the full cost of the exhumation, and payment must be made in advance of the request being facilitated.

### **13.0 Memorials - Erecting, Ownership and Responsibility to Maintain**

- 13.1.1 No memorial will be permitted upon any grave where a burial has not taken place. Certain exemptions may apply to be approved by the Director of Environmental Protection.
- 13.1.2 A grave owner may approach a monumental mason approved by the Council to apply to the burial authority for the Right to Erect a lawn-type memorial onto the head of the grave space. If the application complies with the requirements set out below, then permission will be granted upon the payment of the appropriate fee. A permanent record is made of this transaction in the statutory records. For further guidance concerning the Application to erect a Memorial, refer to Section 13.4.1.

No grave owner or tradesperson may undertake any such work within the cemetery.

#### **13.1.3 Once the memorial has been erected to the standards set out below, the responsibility of the maintenance and upkeep of the memorial lies with the grave owner.**

- 13.1.4 If the burial authority deems the memorial to be unsafe at any time, they will remove the danger by laying the memorial on the ground or by placing a notice upon the memorial. The grave owner will be notified in writing to carry out any necessary repair works to ensure its safety.
- 13.1.5 If the grave owner does not reply to the request to make safe the memorial, then the burial authority may remove the

memorial from the graveside to a place of safekeeping within the cemetery if they think that this action is appropriate.

- 13.1.6 The grave owner must inform the cemetery office of any change of address.
- 13.1.7 Plastic sheeting must not be used to cover a memorial during winter months. The natural stone must be allowed to breathe naturally and plastic sheeting would cause damage to the memorial.

### **13.2 Erection of Memorials on Lawn-Type Graves**

- 13.2.1 If a grave owner chooses to appoint a monumental mason to erect a memorial on the said grave, the contract for this work is between the two parties. If the work becomes defective, then the grave owner must return to the monumental mason to rectify the problem.
- 13.2.2 Once erected, the memorial must remain safe and secure at all times. If the Council deem the memorial to be unsafe, then the grave owner must pay for the necessary repair to the memorial. The following requirements must be adhered to:

#### **Specification for Erecting Memorials**

### **13.3 Foundations:**

- 13.3.1 Memorial foundations are being introduced into the cemeteries, and where they are present, the mason must fix the memorial using the number marker as the centre line of the grave.
- 13.3.2 An appointment must be made with the Bereavement Services Manager at the Cemetery and Crematorium Office to meet the cemetery supervisor to locate and verify the fixing process.
- 13.3.3 Where no foundation exists, the mason will position a steel reinforced concrete slab as NAMM recommendation, positioning on the centre line of the head of the grave before cementing the base and NAMM Fixing of the memorial onto it. The concrete slab must be wide enough to

extend to virgin ground for stability.

### **13.4 Application to Erect a Memorial:**

- 13.4.1 Anyone who owns a grave and wishes to put a memorial on it should contact the cemetery and crematorium office or instruct a monumental mason to do this on their behalf. There is a charge made by the Council for the Right to Erect a memorial on a grave. Only the registered grave owner may give written permission for this work to be carried out. Where the owner has passed away, the next of kin will need to make the application and proof of ownership will be requested and the completion of assignment of ownership must be carried out at this time in the form of a statutory declaration; a fee will be payable for this service.

An application and appropriate fee must be submitted to the office for approval if any additional work is requested on a memorial. This includes additional inscriptions, cleaning renovation, refixing, NAMM fixing, etc.

A lease for the right to erect a memorial on the grave will be issued to the grave owner at this time when permission is granted to erect the chosen memorial.

The length of the lease for erecting and maintaining a memorial will be issued for the same period as any guarantee given by the Monumental Mason chosen by the grave owner to erect the Memorial, the length of the lease should be a maximum of 30 years, as recommended by the Institute of Cemetery and Crematorium Management (ICCM) guidance document 'Management of Memorials' referenced to pages 17/18. Please refer to Section 13.0 for further guidance on Memorials - erecting, ownership and responsibility to maintain.

- 13.4.2 All stonemasons must be members of the Council's Approved Memorial Mason Scheme and be registered with BRAMM or NAMM or an equivalent and must comply with all the Cemetery Management Rules and work within the NAMM code of practice.

- 13.4.3 The Bereavement Services Manager must approve all memorials before they are erected. Full particulars of memorials including a diagram showing all dimensions, the style, the type of stone, the fixing method and grave location, the proposed inscription and any design, including colours of paint and all other adornments, must be given on a form available from the cemetery office. The grave owner must sign the application form.
- 13.4.4 The Bereavement Services Manager retains the right to refuse anything that may be inappropriate or offensive to other grave owners.
- 13.4.5 Photo-ceramic plaques can be fixed onto the memorial and the use of abbreviated and pet names are also permitted i.e. Dad, Grandma etc. Personalised emblems may also be inscribed to add individuality, if inoffensive to other grave owners.
- 13.4.6 If lettering other than English is to be incorporated into the inscription, then the transcript must be attached to the application as proof of the intended wording. The mason and the grave owner must sign the translation to confirm accuracy and true record of proposed wording.
- 13.4.7 Kerbstone sets and under-kerbs are not allowed to be erected onto any new or existing memorial within the cemeteries, palisading or railings and book style plinths are not permitted.
- 13.4.8 If anyone puts a further inscription on a memorial or alters it in any way without first getting a permit from the Bereavement Services Manager, then the Bereavement Services Manager shall be at liberty to remove the memorial from the grave.
- 13.4.9 Any person who carries out any work on a memorial shall remove any waste from the cemetery.
- 13.4.10 All memorials, once erected, remain the property of the grave owner, and the Council will not be responsible for any damage or disrepair which occurs to them unless, of

course, the damage has been accidentally caused by the Council's workmen whilst carrying out their duties. If the Council consider any memorial to be unsafe, then the grave owner must carry out the necessary repair work. Failure to do this will lead to the memorial being dismantled and removed by the Council.

- 13.4.11 Only one memorial can be erected on one grave space. If the grave owner requests an additional vase or tablet, this request may be declined if the positioning would cause obstructions for grounds maintenance. Where an additional memorial is permitted, an additional application and fee will be payable.
- 13.4.12 The Council reserves the right to remove or exclude any memorial that has been erected in an unworkmanlike manner, or that would lower the tone and standard of the surrounding graves.

### **13.5 Dimensions:**

- 13.5.1 The headstone (plate) and base of any memorial may be fixed to a one-piece stone plinth of maximum thickness of 101mm/4 inches in depth, prior to placing it upon the reinforced concrete foundation.
- 13.5.2 The maximum size for any memorial is 1016mm/40 inches in height (excluding stone plinth) and 914mm/36 inches in width. The maximum depth of the memorial base is 304mm/12 inches.
- 13.5.3 Double memorials are allowed, but these will be subject to an additional fee and must not exceed 40 inches (1016mm) in height plus 4 inches (101mm) stone plinth and a maximum 72 inches (1828mm) width.



### 13.5.4 Dimensions and diagram of lawned memorial

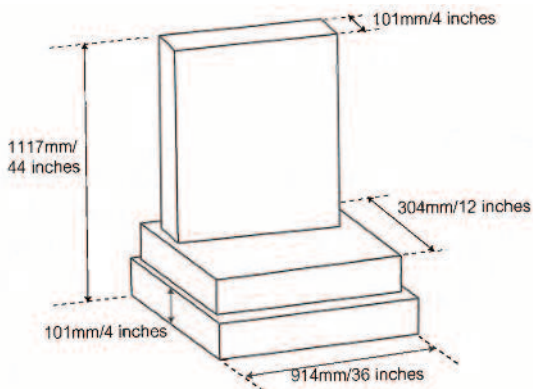

**Note**  
Books, tablets, vases, pots or statues are only to be put on base of memorial (not at the side, on the concrete beam or in front of the lawn area)

**Memorial Specification**

- Maximum height of memorial (including base and stone plinth) = 1117mm/44 inches
- Maximum width of memorial = 914mm/36 inches
- Maximum depth of base (front to back) 304mm/12 inches
- Maximum thickness of memorial = 101mm/4 inches

13.5.5 The maximum height for any statue fixed to a memorial must not exceed 24 inches (610mm) and must be fitted in the appropriate manner.

### 13.6 Specifications:

13.6.1 All stone plinths must be fixed to a foundation that conforms to the relevant British Standards. The plinth base must be properly sealed and pointed so that no cracks appear which would loosen the memorial. The base and plate must be fixed using cement/water mix only.

**13.6.2 No iron, terracotta, plastic or concrete memorials are allowed, only natural materials can be used in the design of the memorial.**

13.6.3 The grave number must be inscribed on the side of the memorial plate where it is visible along with the name of the mason, in letters not exceeding 20mm in height. The grave owner must give his consent to the latter form of inscription but it is important for any mason's work to be identifiable to the burial authority.

Flower vase receptacles may be bored into the base of the memorial to provide for cut flowers. No more than 3 holders

are permitted per memorial, except where the memorial has a square base and it is the family's request to have a vase at each corner of the memorial.

- 13.6.4 All parts of the memorial must be properly secured, one to the other. Stainless Steel dowels and NAMM-approved fastenings (i.e. bolts, ground anchors) **must be used**. The Council reserves the right to instruct the family or the mason to refix, move, line up or alter the position of the memorial to conform with the Council's requirements.

Any item that is fixed to the base, which must be prior approved by the Bereavement Services Manager, must be fixed using dowels and NAMM fixing and must not just be cemented or glued.

- 13.6.5 The memorial must be fixed in accordance with the code of working practice set out by NAMM, paying particular attention to:

### **13.7 Memorial Stability (Section 1) - The basics - (as NAMM Code of Working Practice Requirements)**

#### **13.7.1 Proof Strength**

- Every memorial over 500mm in height shall be erected to withstand a minimum pull/push force of 70kg applied at its apex or, in the case of a tall memorial, at a height of 1500mm (5 foot) i.e. notionally shoulder height.
- The requirements of this code can only be achieved by using one of the methods of fixing listed in Section 3 of the NAMM code of working practice, this means that all memorials must be erected using an accredited fixing method.

#### **13.7.2 Adhesives - All adhesives used**

- Shall conform to the relevant British Standard (BS).
- Shall be confirmed by the manufacturers as being suitable for the purpose.
- Shall be applied correctly on correctly prepared surfaces.

### 13.7.3 Fixings

- All fixings used shall conform to the relevant British Standard (BS) and shall be confirmed by the manufacturers as being suitable for the purpose.

### 13.7.4 Drilling & Filling of Dowel Holes - All dowel holes shall be drilled with great care to ensure the sides of the holes are not fractured in any way.

- Attention shall be given to the careful drilling, filling and sealing of all dowel holes.
- Ensure drill specification does produce the hole size specified.
- A good quality adhesive or cement (see Section 2 of NAMM code of working practice or 13.7.8 below) shall be used.

### 13.7.5 Level

- a) **Memorials** - All memorials shall be set at the proper level for the design, with due allowance being made for sloping ground. There shall be no backward or forward lean unless a specific design dictates.
- b) **Foundations** - All foundations shall be set level, except when allowances are made for sloping ground.

### 13.7.6 Drainage - Provision shall be made for adequate drainage on all memorials and their foundations, as well as in vases and bases.

### 13.7.7 Joint Size - When using cement, all joints shall be constructed to be as tight as possible, any item that may act as a spacer shall be countersunk into one of the adjoining parts.

### 13.7.8 Masons may be required to vary fixing methods if directed by a Structural Engineer employed by the Cemetery/burial authority, or to comply with regulations outside the code. Some Authorities install their own foundations or supply bases. In this case the Mason must comply with instructions for that cemetery. Authorities are entitled to

insist that a memorial be built to current building regulations. In any of these cases the Cemetery must provide a complete specification.

### 13.7.8 Cement (Section 2)

a) **Mixing - Great care must be taken when mixing cement.**

The cement must be mixed to a thick, creamy consistency. Uncontaminated water should be used.

Once the correct consistency has been reached, additional water must not be added, as this is likely to reduce its strength.

b) **Securing Dowels** - When using cement to secure dowels, it is important that the dowel holes are properly filled.

Precautions should be taken to ensure the cement is not allowed to come out of the holes during fixing.

This may require the plate to be held upside down while the dowels are being inserted and until the cement has set.

c) **Surfaces Keyed - All surfaces to be fixed** should be roughened to form a good key for good and lasting adhesion. This applies equally to the memorial plate, base and foundation/s.

d) **Bedding Surfaces** - Except where the design of the fixing system being used dictates otherwise, all meeting surfaces shall be fully bedded.

**Note:** *When using porous stone (e.g. Portland and Sandstone), the stone should be Pre-wetted to avoid hydraulic shock.*

e) **Pointing** - All joints shall be properly pointed.

### 13.7.9 Resins - Great care has to go into the mixing of resins.

a) All the manufacturer's instructions must be strictly adhered to.

b) All surfaces to be joined must be clean, dry and free from dust.

c) When using resin to secure dowels, **it is particularly important:**

(i) that the holes are completely dry, clean and free from dust. **(Note: after drilling the hole, a strong blast of air should be used to thoroughly remove the stone dust).**

(ii) that the dowel holes are properly filled.

Precautions shall be taken to ensure the resin is not allowed to come out of the holes during fixing.

This may require the plate to be held upside down while the dowels are being inserted and until the resin has hardened.

#### **13.7.10 Work Permits:**

(i) When the Bereavement Services Manager has approved a memorial, then a permit will be issued so that the memorial can be erected. No memorial is to be erected unless a permit has been issued. If a memorial is erected without permission being given, then that memorial will be removed forthwith.

(ii) All new memorials must be completed away from the cemetery and brought to the cemetery fully inscribed and polished. The memorial must be conveyed into the cemetery using the appropriate equipment in a dignified manner. The Bereavement Services Manager may at any time inspect the memorial at the monumental mason's workplace. Only the NAMM fixing of the memorial may be carried out in the cemetery.

(iii) Any memorial which has not been made or inscribed as first indicated or which has not been made in a workmanlike manner will either not be allowed to be erected or, if it has already been erected, will be removed.

- (iv) No work is permitted on any memorial except on Monday to Thursday between the hours of 9.00am and 4.00pm, and Friday between the hours of 9.00am and 3.00pm. No work is permitted to be undertaken on Saturdays, Sundays or Bank Holidays. The mason should call into the office to view the plans if clarification of the position and location of the grave is required prior to making an appointment with the Bereavement Services office to fix any memorial in the presence of the cemetery supervisor to verify memorial works.
- (v) No memorial may be altered in any way after it has been erected in accordance with the approved design, except for further inscriptions which may be cut provided that these have been first submitted to the Bereavement Services Manager for approval and a permit has been issued. The memorial may then be removed for the inscription to be carried out or the inscription may be done on site.
- (vi) No memorial may be erected adjacent to any funeral taking place. The memorial may only be erected after the dispersal of the mourners. Any ground marks made by the mason must be covered before leaving the cemetery, and the area must be left in the same condition as before the work commenced.
- (vii) Only monumental masons and Council employees who have been approved to work in the Council's cemeteries may carry out any memorial work on behalf of the grave owner. The mason must provide the Council with details of his Employer's and Public Liability Insurance, along with a Method Statement, Risk Assessment, Health and Safety Policy and copy of written guarantee of his work. A list of approved masons is available for inspection in the cemetery office.
  - Grave owners and other tradespersons are not allowed to carry out any memorial work within the

cemeteries. Only suitably skilled craftsmen will be permitted to erect memorials, inscriptions, renovations or repairs. An application for these additional works must also be submitted to the Bereavement Services Manager for approval.

- The Council reserves the right to escort any unauthorised person from the cemetery.

### **13.8 Memorial Insurance**

The erection of a memorial is at the sole risk and responsibility of the grave owner. Bereavement Services strongly advise all grave owners to insure their memorial. The cemetery office or the mason can advise accordingly.

- 13.9 Any memorial mason who undertakes any work within the Council's cemeteries must be able to guarantee their work for a minimum of 10 years.

## **14.0 Temporary Grave Markers**

- 14.1 When a grave owner cannot afford a permanent memorial after the interment, an application for the purchase of a temporary marker cross can be made to the Cemetery and Crematorium Office. A small personalised plaque is included in the purchase price.
- 14.2 Only crosses purchased from the Council can be erected on a grave. The Council will remove any unauthorised memorial crosses with the exception of Remembrance Day crosses, which may be placed at the head of the grave at the appropriate time of the year.
- 14.3 This marker may remain on the grave for a period not exceeding 12 months from the time of purchase of the cross. After the expiry of the 12 months, the Council will write to the grave owner to notify them of the expiry period and give them two weeks' notice.
- 14.4 The grave owner may take the cross away from the cemetery.
- 14.5 If no response is given to the correspondence, the Council reserves the right to remove the cross from the grave. The application and fee payable to erect the temporary cross must be made to the Cemetery and Crematorium Office.
- 14.6 The grave owner must inform the cemetery office of any change of address.
- 14.7 The Council shall not be held liable for any loss of, or damage to, any temporary grave marker while in the cemetery or crematorium, however such loss or damage may be sustained, except where such loss or damage is caused by the negligence or recklessness of a representative or employee of the Council.
- 14.8 Failure by the Council to give notice of removal of a temporary grave marker shall not cause the temporary grave marker to become an authorised memorial for the purpose and protection of the Order.



- 14.9 A temporary grave marker may be removed any time after the expiry of any period of permission, provided that a period of two weeks' notice has been served on the owner. The temporary grave marker will then be stored for 6 months prior to collection from the grave owner and disposed of after the expiry of this time, if not collected.
- 14.10 These rules and regulations shall apply to a temporary grave marker whilst it remains within the cemetery or crematorium grounds.

## **15.0 Maintenance and Care of Graves and Memorials**

- 15.1 Anyone who owns a grave, which contains a memorial, must keep the memorial in a good state of repair.
- 15.2 Anyone who owns a bricked grave or vault must keep it in a good state of repair.
- 15.3 If a memorial, kerb-surround or the brickwork of a grave or vault becomes damaged or defective and in need of repair, then the Council will contact the owner. At this time, the owner will have the choice of carrying out the necessary repairs or having the memorial removed by the cemetery staff.
- 15.4 If a memorial becomes dangerous, then the Council will make it safe even if this means laying it down on the grave until the grave owner can be contacted.
- 15.5 From time to time, circumstances arise where defective memorials can be remedied by carrying out minor repairs.
- 15.6 In these cases, the Council may choose to do this work on the grave owner's behalf free of charge as part of the routine day-to-day repair and maintenance work of the cemetery. A record will be made of any remedial works undertaken.
- 15.7 Any person who attends to a grave shall deposit any waste or rubbish produced into the waste bins provided in the cemetery.
- 15.8 It is not permitted for any iron, plastic, wooden or other type of railing or fence, brickwork, stonework, toys, windmills or ornaments to be erected on any part of a grave. Large flags on flag poles will not be permitted to be erected on any grave space. Neither is it permitted to use glass jars and containers to arrange cut flowers.
- 15.9 Jars, glass bottles or ornamental stones or shells etc. or any other article, which the Bereavement Services Manager considers unsightly or dangerous, will be removed.

- 15.10 The Bereavement Services Manager is authorised to remove any of the items described in 15.8 and 15.9 above but firstly a letter will be sent to the grave owner where possible or notice placed on to the grave giving two weeks' notice and an opportunity for the grave owner to remove the items. Where graves have become neglected and the Council carry out any work to the grave, the cost may be recharged to the grave owner.
- 15.11 Any item removed by the Bereavement Services Manager will be kept safe for a period of six months, but if not collected by the grave owner during that time, it will be disposed of.
- 15.12 The Bereavement Services Manager may at their discretion remove and dispose of such articles and flowers, plants or wreaths which may be withered or dead.
- 15.13 The Council may, SUBJECT in all respects to Article 16 and Schedule 3 of the Local Authorities Cemetery Order 1977:
- (a) remove from the cemetery and destroy:
    - (i) Any tombstone or other memorial on a grave of which all material particulars are illegible or which is dilapidated by reason of long neglect.
    - (ii) Any kerb surrounding a grave (whether containing any commemorative inscription or not) together with the foundation slabs of such kerbs.
    - (iii) Any tombstone or other memorial, not falling within (i) or (ii) on a grave, except where the owner of the right to place and maintain it in the cemetery has requested that it shall be re-erected in the cemetery or elsewhere.
    - (iv) Any surface fittings not falling within (i), (ii) or (iii) above or any flowering or other plants, on a grave; and
      - Any railings surrounding a grave, a tombstone or other memorial on a grave or a grave space.

- Alter the position on a grave of, or re-erect at another place in the cemetery or elsewhere, any tombstone or other memorial on a grave.
- Level the surface of any grave, other than a grave described in paragraph 2 of the said Act, to the level of the adjoining ground.
- Alter the position of any railings surrounding a grave or vault, a tombstone or other memorial or grave space.
- Re-erect at another place in the cemetery a memorial other than one on a grave or vault or in a chapel provided as mentioned in Article 6 (1) (b) of the Order.

15.14 No person shall remove, alter or disturb any monument or other gravestone erected or placed within the cemetery or crematorium without the consent of the Bereavement Services Manager.

## **16.0 Cremated Remains Graves**

- 16.1 These graves are for the interment of cremated remains only.
- 16.2 Up to 6 sets of cremated remains may be buried or poured loosely into each grave space. An alternative cremated remains section has been set aside in the Cemetery Extension which can hold up to 4 sets of cremated remains please refer to Section 12.9 Cemetery Extension paragraph 12.17 Cremated Remains graves (Section 78/79) without extended garden.
- 16.3 The interment arrangements must be organised through the cemetery and crematorium office and the paperwork and notice regulations (as Regulation 8) must be applied in the same way to this area.
- 16.4 The Exclusive Right to Burial is granted to the designated grave owner (as per Regulation 7).
- 16.5 A memorial may be erected on the concrete foundation at the head of the grave. The measurements must not exceed 914mm/36 inches in width x 304mm/12 inches in depth and must not be higher than 1016mm/40 inches which must include any one piece plinth between the foundation and base.
- The plinth size must be adjusted according to the size and style of the memorial. The maximum dimensions are 900mm in length x 300mm in width x 100mm in depth.
- 16.6 Only natural materials may be used in the construction of the memorials. An application to erect a memorial must be made through the monumental mason to the cemetery and crematorium office (as per Regulation 13). All memorials must only be erected in accordance with the cemetery regulations and in accordance with the NAMM code of practice, refer to 13.5.4 for dimensions and diagram of lawned memorial.
- 16.7 If the owner of the grave wishes to plant a small garden at the head of the grave, then this is allowed, as long as the garden area does not exceed 12 inches from the

headstone into the grave, nor does it exceed 36 inches in width (300mm x 900mm wide). This area must not be enclosed with small kerb edgings of any description, and only small plants that will not reach a height greater than 18 inches/450mm on maturity shall be planted in this area.

- 16.8 The graves must not be embellished with any other forms of ornamentation or memorial e.g. toys, pictures and frames, pebbles, kerbs, additional vases and plastic trees.
- 16.9 The Bereavement Services Manager is authorised to remove any of the items described in 15.8 and 15.9 above but firstly a letter will be sent to the grave owner where possible or a notice placed onto the grave giving two weeks' notice and an opportunity for the grave owner to remove the items. Where graves have become neglected and the Council carry out any work to the grave, the cost may be recharged to the grave owner.
- 16.10 Any item removed by the Bereavement Services Manager will be kept safe for a period of six months, but if not collected by the grave owner during that time, it will be disposed of.
- 16.11 Where grave owners would like to personalise their grave and extend the garden area, the Bereavement Services Manager will allow families to create a garden area, which must not exceed 3 feet in width by 24 inches in depth. This garden area may also be adorned with kerb edgings, foot kerbs, statues, ornaments, vases or any other form of memorialisation, at a request to the Cemetery and Crematorium Office.

**All Grave Owners** who wish to **extend and adorn their grave must seek permission** from the Bereavement Services Manager and **must sign a declaration** in the Cemetery and Crematorium Office to agree to abide by the regulations and ensure that the areas of grass where the mowing machinery cannot access, because of this form of adornment, are cut and maintained to the same standard as the adjacent graves.

The Bereavement Services Manager retains the right to remove any such item from a garden area, which is not suitable for display.

Failure to comply with these regulations will lead to the Bereavement Services staff removing any such item from the grave area without any prior approval of the grave owner. All grave owners must comply with St.Helens Council's Cemetery and Crematorium Rules and Regulations.

16.12 Pre-purchase of graves shall be limited to one grave per purchaser, in advance of burial.

If a burial is to take place within a new grave, and the pre-purchase of an adjacent grave is requested, only one grave will be permitted to be purchased.

The Council reserves the right to refuse any pre-purchase of a grave, at its sole discretion.

## **17.0 Cremation Documentation**

- 17.1 Cremations are carried out at St.Helens Crematorium. The times at which cremations take place are listed in Regulation 6.2 and can be arranged at half hourly intervals.
- 17.2 Cremation times may be booked by telephone but no cremation can take place until the Medical Referee for St.Helens Council, (who is a registered Medical Practitioner of not less than 5 years standing, appointed by the Home Secretary), has given his authority in Form Cremation 10 for the cremation to proceed once all the legal forms have been submitted to him. The Medical Referee may, decline the request to cremate, but must offer a reason for this in writing to the applicant for cremation.
- 17.3 Forms Cremation 1, 4 and 5, 11 or 7 (in remote cases) together with the Certificate of Disposal issued by the Registrar of Births and Deaths or where the Coroner has been involved or an inquest has been held, the Coroner's Certificate in Form Cremation 6 or the Home Office licence to proceed and the certificate of No Liability to Register must be delivered to the Bereavement Services Manager no later than 9.30am on the working day prior to the cremation, along with the appropriate fee.
- 17.4 The Bereavement Services Manager also needs to have details of how the service in the chapel is to be carried out and how the ashes are to be dealt with, in the form of the 'Preliminary Application for Cremation'. This should be delivered along with the legal forms on the working day prior to the cremation. This form must be signed by the applicant for cremation to confirm the method of disposal of the ashes, and the Funeral Director must sign the declaration on the reverse of the form before the form will be accepted.

## **17.5 Stillborn Cremations**

- 17.5.1 Form Cremation 3 along with the Medical Form Cremation 9 from the hospital and the "Certificate of Stillbirth" from the Registrars of Births Deaths and Marriages, and the



preliminary form must be delivered to the cemetery and crematorium office on the working day prior to the cremation, before 9.30am before the funeral may proceed. Form Cremation 13 is also required to be completed by the Medical Referee.

- 17.5.2 There is no guarantee that any remains will be visible after the cremation, and therefore the family must be advised of this, however every effort will be made by the crematorium staff to recover tangible ashes from the cremation of the stillborn child.

## **17.6 Cremation of a Foetus**

An application form and preliminary form must be signed by one of the parents, the hospital will issue a confirmatory notice (this takes the place of Forms Cremation 4 and 5) and these forms must be delivered to the office by 9.30am on the working day prior to the cremation. There will be no tangible remains after the cremation, but every effort will be made by the crematorium staff to retain the residue from the cremation.

## **17.7 Cremation of Human Tissue**

The cremation may take place of any human tissue that was removed from a deceased person in the course of scientific research or testing.

An application form (Form Cremation 2) must be completed by the nearest surviving relative of the deceased and Form Cremation 8 must be completed by the hospital authorities. Form Cremation 12 is also required to be completed by the Medical Referee. The preliminary notice must be completed and all forms must be delivered by 9.30am on the working day prior to the funeral.

There will be no tangible remains after the cremation, but every effort will be made by the crematorium staff to retain the residue from the cremation.

A fee will be imposed for this service request.

## **18.0 Construction of Coffins used for Cremation**

- 18.1 Coffins used for cremation must comply with the requirements of the Federation of Burial and Cremation Authorities a document entitled 'A guide to Cremation and Crematoria' can provide further guidance, the Secretary of State's Guidance notes of the Environmental Protection Act 1990 or any subsequent legislation made thereunder. Most coffins are now commercially produced to the required standard which is as follows
- 18.1.1 The Funeral Director shall observe the regulations of the Cremation Authority at all times. The Funeral Director shall pay particular attention to the coffin construction and any items placed within the coffin, the Funeral Director will sign a declaration to accept the terms and conditions of the cremation, within the Instruction for Cremation and confirm that the coffin and its fittings conform for cremation.
- 18.1.2 The coffin must be made of wood or a wood by-product which, when placed in a cremator and subjected to the accepted cremation processes, is easily combustible and which does not emit smoke, give off toxic gas or leave any retardant smears or drips after final combustion.
- 18.1.3 No metal furniture or fittings whatever shall be used on a coffin for cremation or placed within the coffin. Coffin handles should be free from unnecessary metal components.
- 18.1.4 No metal of any kind shall be used in the manufacture of such coffin except as necessary for its safe construction and then only metal of a high ferrous content.
- 18.1.5 Cross pieces shall not be attached to the bottom of the coffin. If it is desired to strengthen the bottom of the coffin, wooden strips may be placed lengthways for this purpose; however the bottom of the coffin/casket must be flat.
- 18.1.6 External coatings to a coffin must allow for smokeless combustion and the use of nitro-cellulose varnish; polyurethane, melamine and any products containing

polyvinyl chloride (PVC) or melamine must not be used in coffin construction or furnishings. Water based lacquer free from additives containing heavy metals may be used for coating a coffin or a suitable cloth may be used for covering the coffin.

- 18.1.7 The exception to the above is the use of polystyrene which is restricted to the coffin nameplate only and this must not exceed 90 grams in weight.
- 18.1.8 The use of sawdust, cotton wool or shredded paper within a coffin lining must be avoided. If lining of a coffin is necessary, this should be manufactured from polythene not exceeding 75 microns in thickness. Lead or zinc linings must not be used. The use of shredded paper within a coffin is not permitted.
- 18.1.9 The Funeral Director must contact the Bereavement Services Manager immediately if the external measurements of the coffin are likely to exceed 80 inches (203cms) in length; 28 inches (71cm) in width; 18 inches (46cm) in depth or is 20 stone (280 lbs /127 kg) or above in weight. The maximum size of a coffin/casket that can be cremated is 7 foot in length; 32 inches wide; 18 inches deep (2100mm x 800mm x 450mm) and the cremation will be declined if the coffin cannot be cremated safely.
- If the coffin is larger than 30 inches wide then this cremation must be booked as the first cremation of the day due to this cremation requiring to be manually charged.
- 18.1.10 The Funeral Director must confirm the coffin dimensions on the preliminary notice, and must also inform the Bereavement Services Manager if own clothing or personal items are requested to be placed in the coffin. The Bereavement Services Manager has the right to refuse any such items that emit smoke and particulates from the cremation cycle. In order to minimise the release of pollutants to air, it is recommended that clothing should be of natural fibres and that shoes or any material manufactured from PVC should not be included. Any

rubber or leather garments must be avoided. Photographs and cards may be placed in the coffin, but picture frames, glass, bottles, aerosols, or pressurised containers, and shredded paper particularly must not be included due to particulates emissions and the breakdown of the cremation process.

- 18.1.11 Every coffin must have a nameplate fixed to it and the name on the nameplate must be that of the deceased person being cremated. Handles must also be fitted so that the coffin can be conveyed safely into the cremator.
- 18.1.12 The Bereavement Services Manager must be advised prior to the booking of any non-standard coffins e.g. wool coffins, wicker coffins, etc.

The base on any wicker coffin must be completely flat to enable the coffin to be charged safely.

The Cremation of these types of coffins must take place early in the day and therefore the cremation service should be the first of the day to ensure the Cremator is at its coolest and for the coffin to be charged safely.

For further guidance please refer to the Institute of Cemetery and Crematorium Management (ICCM) Green/Environmental Coffins.

## **19.0 Services in the Crematorium Chapel**

- 19.1 Religious services or ceremonies prior to cremation may be performed in the Crematorium Chapel provided that they are conducted reverently and the use of the chapel for this purpose is included within the Council's cremation fee.
- 19.2 Cremations are booked at 30-minute intervals but a service shall not last longer than 20 minutes unless specifically agreed otherwise by the Bereavement Services Manager, five minutes either side are allowed for seating and escorting the family from the chapel. An additional 1/2 hour period may be booked to give a longer period for the service, which will incur an additional fee for extended chapel use. This is however recommended when more than three pieces of music are requested and special requests are made this will ensure the bereaved family have enough time to carry out their wishes without being restricted to a twenty minute time slot.
- 19.3 The Funeral Director and the Crematorium Attendant are jointly responsible for making sure, so far as possible, that services do not overrun the allotted time and make the following funerals late. The Funeral Director must comply with all reasonable requests and instructions given by the Crematorium Attendant, which are aimed at preventing this.
- 19.4 If families request their own CDs or USB connection to be played during the service, they must be delivered with the paperwork on the day prior to the funeral to allow the staff to check for sound quality. The Bereavement Services Manager has the right to refuse any request at the time of the funeral service, if the recording arrives late, is offensive or is poor in quality. The minister conducting the service should have been informed of the music choice prior to the service taking place.

An electric organ is situated in the Crematorium Chapel, which may be used during the funeral service. The Funeral Director is responsible for organising and paying an organist for their work.

- 19.5 The chapel can seat up to 120-140 mourners. Where the Funeral Director knows that a large funeral service is imminent, the Bereavement Services Manager must be made aware of this, so that traffic control measures can be implemented
- If mourners exceed this number, they must be encouraged to gather outside the building and must keep all fire exits clear during the service.
- 19.6 Once the service has finished, the coffin must not be removed from the crematorium building.
- 19.7 On arrival at the crematorium the Bereavement Services Manager could decline the acceptance of the coffin if it does not comply with the Environmental Protection Act 1990 guidance notes or any subsequent legislation made thereunder.
- 19.8 Where a funeral is overrunning the allotted time, the following funeral cortege should park in the porte-cochere and await instruction from the chapel attendant to proceed into the crematorium.
- 19.9 An additional fee will be charged at the discretion of the Bereavement Services Manager, when funeral services seriously overrun the allotted time, if this causes interference of one funeral with another or gives the Council added expenditure.
- 19.10 It is the responsibility of the Funeral Director to arrange for the coffin to be placed onto the Chapel catafalque (the place for the resting of the coffin whilst the service takes place) and the Funeral Director must provide sufficient staff (bearers) for this purpose.

## **20.0 Cremation Process**

- 20.1 Cremations will to be carried out according to 'The Code of Cremation Practice' which has been set out by the Federation of Burial and Cremation Authorities (FBCA). St.Helens crematorium is a member of the FBCA.
- 20.2 If representatives of the deceased person ask to see the coffin placed into the cremator this will be permitted but generally will be limited to two persons only, however if more persons are requested to be present this will be at the discretion of the Bereavement Services Manager. This request must be made before the day of the funeral.
- 20.3 No member of the public will be permitted to be in the cremating room whilst cremation is taking place.
- 20.4 By prior arrangement, any member of the public can inspect the crematorium building and relevant questions and answer sheets are available which will allay any misconceptions about the cremation process.

## **21.0 Final Disposal of Cremated Remains (Ashes)**

- 21.1 The Council will wish to know how to dispose of the cremated remains of persons who have been cremated, and details of this are requested on the "Preliminary Application for Cremation" form as follows:-
  - 21.1.1. Scattered in the Memorial Garden Rose Bed or lawned area or poured in the ground or scattered in the Garden of Remembrance or other designated area. The seasonal scatter beds in the Memorial Garden are restricted to family members who already have existing family members laid to rest in this area.
  - 21.1.2 Held for one month to await further instruction and then scattered if no further instruction received.
  - 21.1.3 Buried or poured in a private grave at St.Helens or Newton-le-Willows Cemeteries.
  - 21.1.4 Collected by the Funeral Director or the Cremation Applicant.

**The applicant for cremation must sign the form and the Funeral Director must also sign the reverse of the form before the office will accept it.**

- 21.2 If cremated remains are required to be buried in the Gardens of Remembrance, an appointment can be made, or if the burial is to be unwitnessed, this will be done one month and one day after the cremation. The Gardens are lawned and the ashes are buried just below the surface of the turf. Floral tributes or wreaths must not be placed on the grassed lawned areas at any time.
- 21.3 Scattering of cremated remains in the Memorial Garden takes place on the four main beds, Spring, Summer, Autumn and Winter either with or without an appointment the season bed may be chosen by family members who already have family members scattered in seasonal beds. There is also a special bed dedicated for the scattering of Baby cremated remains.



- 21.4 Scattering of cremated remains is to be carried out within the Cemetery as per the 'Code of Cremation Practice' of the FCBA (Federation of Burial and Cremation Authorities) by or under the Supervision of the Bereavement Services Team and by no other person.
- 21.5 There is a monthly charge made for the storage of cremated remains for longer than one month at the crematorium. The Funeral Director should collect the cremated remains from the crematorium as soon as possible.
- 21.6 Cremated remains may not be buried in a grave unless the Bereavement Services Manager has been informed and the legal forms for this have been completed. The Bereavement Services Team then carry out the operation and the appropriate fee will apply as per Regulation 8.
- 21.7 It is an offence to dispose of cremated remains within the grounds of cemeteries, without the knowledge or permission of the Bereavement Services Manager. The final resting place of all cremated remains must be recorded in the statutory registers.
- 21.8 Memorial niches are also available on an initial lease of ten years which can be renewed at the end of the term for an extension period. The memorial niche can hold a maximum of two sets of cremated remains (ashes).
- 21.9 Any person who wishes to collect cremated remains from the crematorium must first apply to the Bereavement Services Manager for a "Cremated Remains Certificate". This certificate is only issued to the person who has signed the cremation forms or to the Funeral Director who has arranged the funeral. The cremated remains will normally be ready to collect on the working day after the funeral. It may not be possible to collect cremated remains on the same day. The Bereavement Services Manager will advise accordingly.

Where cremated remains are being held to await instructions, the Funeral Director must remind the family to make a decision. Where the family cannot decide, the Funeral Director must remove the cremated remains from the Authority once the applicant has signed the preliminary form. The family may then take their time to make the right choice for the cremated remains.

- 21.10 Suitable containers for cremated remains (ashes) can be purchased from the Bereavement Services Manager. Otherwise, the person collecting them must have a container, which is fit and proper for the purpose. If the Crematorium Attendant feels that the container is not fit and proper, then he will not release the ashes. In no circumstances will the ashes be split into different containers. Containers must be of at least 3250 cubic centimetres capacity.
- 21.11 A duplicate cremated remains certificate can be arranged by the Cemetery and Crematorium office if the original becomes lost and a fee is payable for the duplicate certificate.
- 21.12 Sanctum 12 and Sanctum 2000 Columbarium Niches are available within the Cemetery extension for the Interment of Cremated Remains (ashes). These niches each hold two caskets of Cremated Remains (ashes). A lease period of either 10 or 20 years can be purchased. At the end of the lease period the lease can be renewed or the Cremated Remains (ashes) removed to a location of choice by the owner of the niche

## **22.0 Floral Tributes left at the Crematorium**

- 22.1 Floral tributes from funeral services, if not collected by the Funeral Director, will be removed from the Floral Tribute Area and disposed of five days after the funeral service by the grounds maintenance staff.
- 22.2 The Council cannot be held responsible for any floral tributes that cannot be found. Floral tributes are left at the family's own risk.
- 22.3 Floral tributes transferred to a grave are conveyed at the risk of the cremation applicant and no liability can be accepted by the Council for any loss of, or damage to, any floral tribute, which may be sustained.

## **23.0 Floral Tributes left in the Gardens of Remembrance**

- 23.1 Floral tributes left in the Gardens of Remembrance or Memorial Gardens at St.Helens Crematorium or Newton-le-Willows Cemetery will be removed and disposed of when, in the opinion of the Bereavement Services Manager, they have become withered or unsightly or it is necessary to facilitate grounds maintenance.
- 23.2 No floral or other tribute shall be placed in the Chapel of Remembrance at St.Helens Crematorium or Newton-le-Willows Cemetery. Any such item may be removed by the Bereavement Services Manager and disposed of without further notice.

## **24.0 Floral Tributes - Christmas and other Religious Festivals**

- 24.1 Christmas wreaths and tributes marking other religious festivals may be placed at any memorial or designated location and may remain for a suitable period determined by the Bereavement Services Manager. At the end of the religious period, tributes will be cleared away and disposed of by cemetery staff. Alternatively, individuals with the prior approval of the grave owner may remove tributes.

## **25.0 Books of Remembrance**

- 25.1 The Books of Remembrance are kept in the Chapel of Remembrance, which is a separate building from the crematorium at St.Helens, or within the Newton-le-Willows Burial Chapel at Newton-le-Willows Cemetery. Inscriptions in the book may be made upon payment of a set fee.
- 25.2 The pages of the book are turned daily to the corresponding date of the year. The book may be inspected at all times when the chapel is open. (See Regulation 5 for these times.) The pages may be turned, upon request, to a different date.
- 25.3 Cut flowers may be placed in the receptacles provided. No other items are allowed to be left in these areas.

## **26.0 Memorialisation**

- 26.1 The Council provides various forms of memorialisation within the grounds of the crematorium. Bereaved families may request one of these forms of memorialisation by making written arrangements with the cemetery office.
- 26.2 Where possible, families may choose the position of their memorial.
- 26.3 The memorials are leased over a period and a lease document is issued to the family after the payment for the memorial has been made. The memorial may be re-leased after the expiry of the initial lease period.
- 26.4 Additional personal items are not allowed to be placed adjacent to the memorial, once positioned.
- 26.5 Memorials in these areas must only be purchased through the Council; families are not permitted to bring their own memorials into the cemeteries or crematorium grounds. Any memorial that is brought into the Gardens of Remembrance areas without the knowledge or permission of the Bereavement Services Manager will be removed by the Council without prior warning and stored for collection in the cemetery and crematorium office.
- 26.6 Three months prior to the expiry of a period of lease, the Council will contact the owner, where possible, inviting the owner to renew the lease.
- 26.7 Where it is not possible to contact an owner of a lease, or in cases where such owner declines to renew the lease, the Bereavement Services Manager may, on expiry of the lease, remove and place in storage the leased memorial.
- 26.8 A leased memorial placed in storage by the Bereavement Services Manager will be held for one month from the date of expiry, during which time the lease owner may collect the item or renew the lease. After one month, the Bereavement Services Manager may dispose of the item.

## **27.0 General conditions which apply to all persons visiting the Cemeteries**

### **27.1 Dogs**

- 27.1.1 Dogs must be kept on short leads and under control and no person is to allow a dog to walk onto any grave. Dogs are only permitted into the cemetery where the owner is visiting a grave. Dogs must not be exercised in the cemeteries.
- 27.1.2 Any person who allows a dog to foul any part of the cemetery must immediately pick up the fouling and use the dog bins provided or remove it from the cemetery.
- 27.1.3 No dog, other than a guide dog, is permitted in the burial or crematorium chapels.

### **27.2 Vehicle Users and Horse-Drawn Hearse**

- 27.2.1 All vehicle users must observe and adhere to the official entry, exit and one-way systems, which are in place.
- 27.2.2 Motor vehicles and horse-drawn hearse must not be driven faster than 5 miles per hour within the cemetery and must keep to the main carriageways. Riding motorbikes and quad bikes in the cemeteries is prohibited. Cyclists must only enter the cemeteries to visit graves and must pay due respect to the surrounding area.
- 27.2.3 Vehicles must use the car park and must not block any path or road. Vehicles must not mount or park on grass verges or burial plots.

### **27.3 Visitors**

- 27.3.1 All persons visiting the cemetery or crematorium shall be expected to conduct themselves in a quiet and orderly manner. Persons may only enter the office building or mess room when conducting official business. Only the official entry and exit gates must be used to access the cemeteries.



- 27.3.2 No unaccompanied children under the age of 16 years are allowed in the cemetery unless visiting a specific grave.
- 27.3.3 No person shall in any way interrupt, delay or disrupt the decent and solemn burial or cremation of a body.
- 27.3.4 No person shall play at any game or sport within a cemetery.
- 27.3.5 No person shall fire a gun in a cemetery, except at a military funeral with the permission and notification of the Bereavement Services Manager.
- 27.3.6 No demonstration of any kind or any religious service, except for services held at the time of burial or cremation, shall be held in a cemetery unless prior written permission has been obtained from the Bereavement Services Manager.
- 27.3.7 No band or any musical entertainment will be permitted in a cemetery unless this is for a special occasion and prior permission has been obtained from the Bereavement Services Manager, allowing a minimum of one clear day's notice.
- 27.3.8 Disabled access is permitted within the cemetery grounds during the permitted hours by swipe card entry to lower the automated bollard control system. Swipe cards can be obtained from the Bereavement Services Manager.
- 27.3.9 No person, other than a person tending a grave, shall remove any plants or flowers from a grave in the cemetery.
- 27.3.10 No person shall remove any plants or flowers from any public part of the cemetery.
- 27.3.11 No person shall trade, advertise or carry out business of any kind within the cemetery grounds without prior permission from the Bereavement Services Manager.
- 27.3.12 No person shall hand out religious messages or make attempts to influence anyone's religious beliefs within the cemetery.
- 27.3.13 No person shall use any of the roads or paths through the

cemetery for the transport of goods or materials not intended to be used in the cemetery.

- 27.3.14 No person shall drop litter in the cemetery.
- 27.3.15 No animal shall be left on its own within the cemetery, even if it is tied or tethered.
- 27.3.16 All persons visiting the cemetery must comply with any reasonable request or instruction of any Council employee, if it is made in the interests of good order within the cemetery.
- 27.3.17 No person must climb on, or deface or damage, any memorial. Neither must they damage nor vandalise perimeter walls, fences, gates, any cemetery building or any planted shrub or trees.

#### **27.4 Use of Cameras**

- 27.4.1 The use of still, cine, video, digital and television cameras is strictly prohibited at or near any grave before, during or after an interment. Such equipment shall not be used to photograph mourners or any part of a funeral cortege within the cemetery, without permission of the Bereavement Services Manager. Such permission will not normally be granted without the prior consent of the next of kin of the person being interred and, in the case of television cameras, prior consent of the Director of Environmental Protection. This regulation also includes the Crematorium Chapel.
- 27.4.2 Subject to the above exceptions still, cine, video, digital may be used in the cemetery but, if it is intended to publish the photographs or videos obtained or use them for advertising, a permit must first be issued by the Bereavement Services Manager, and in the case of photographs of memorials taken for such purposes, the Bereavement Services Manager will require the written consent of the grave owner and the monumental mason. Television cameras shall not be brought into the cemetery or crematorium grounds without the prior consent of the Director of Environmental Protection.

27.4.3 Monumental masons may take digital camera pictures of memorials with the consent of the grave owner.

## **27.5 Gratuities**

The receipt of a gratuity by an employee of the Council, under any pretext whatever, is strictly prohibited.

## **28.0 Removal and Prohibition from a Cemetery**

- 28.1 The Council may remove from the cemetery any person who contravenes any of the documented regulations and may prevent that person from re-entering it.

## **29.0 Religions, Beliefs and Faiths**

- 29.1 Every effort will be made by the Bereavement Services Manager to facilitate any reasonable request made by any member of the community concerning any religion, belief or faith with reference to requests for burial or cremation.
- 29.2 St.Helens Council has corporate equality policies in place to ensure that all service users are treated fairly and equally at all times.

## 30.0 Local Authorities Cemeteries Order 1977 (LACO)

- 30.1 It is important that any person who uses the Council's Burial and Cremation Services or who visits a cemetery is aware of the above Order. This is an Order issued by the Government and is made under an Act of Parliament (The Local Government Act 1972). The Order sets down both how a Council has to run a cemetery and what it **can** do or **must** do to preserve good order in a cemetery. The main points of the Order which are, it is felt, appropriate and proper to note alongside the Cemetery Regulations have been converted, so far as possible, from their legal phrases into plain English. These are as follows:
- 30.1.1 The Council may do anything that is considered necessary for the proper management of the cemeteries it controls.
  - 30.1.2 The Council may lay out a cemetery in any way it thinks fit and may improve it if it wishes.
  - 30.1.3 The Council may reserve parts of a cemetery for particular religions and may apply to the Church of England for parts of the cemetery to be consecrated.
  - 30.1.4 The Council must make sure that there is also space within a cemetery for use by persons with no religious belief.
  - 30.1.5 The Council must, by law, keep detailed records of all burials and cremations.
  - 30.1.6 The Council may charge such fees as it thinks is proper for the services it offers in respect of burial and cremation, and must keep a table which shows these charges. The table must be made available to anyone who wishes to see it.
  - 30.1.7 The Council may make a cemetery into a lawned cemetery, and provided that the proper procedure has been gone through, then the gravestones may be removed. The Council has a policy that all new graves are of the lawn type (with the exception of Section 89), but headstones are

permitted to be placed at the head of the grave space.

- 30.1.8 The Council **must** make safe any memorials which have become dangerous and it may remove any memorials which have become dilapidated, but in this latter case there is a proper procedure to be gone through which is quite lengthy.
- 30.1.9 No burials can take place without permission of St.Helens Council.
- 30.1.10 There are standard conditions which relate to the depth of burial and the nearness of one coffin to another.
- 30.1.11 The maximum time for which the Council may grant a grave is 100 years.
- 30.1.12 Article 18 (l): No person shall -
- (a) Wilfully create any disturbance in a cemetery.
  - (b) Commit any nuisance in a cemetery.
  - (c) Wilfully interfere with any burial taking place in a cemetery.
  - (d) Wilfully interfere with any grave space, or vault, or tombstone or any other memorial, or any flowers or plants.
  - (e) Play at any game or sport in a cemetery.
  - (f) Unless authorised, remain in a cemetery when it is closed to the public.
- 30.1.13 If anyone is found guilty in a court of contravening anything listed in item 31.1.12 (a-f), then they are liable to a maximum fine of £100 for each offence, and if the offence continues there is a further fine of up to £10 per day until the offence ceases.

## **31.0 Fines and Penalties**

31.1 The Council has the power to take to Court persons who contravene any of the above Regulations, which also come under the scope of the Local Authorities Cemeteries Order 1977. If convicted, the maximum fine for each offence is £100, and if the offence continues there is a further fine of up to £10 per day until the offence ceases.

## **32.0 Extent of Regulations**

32.1 The Council reserves the right, from time to time, to make alterations to these Cemetery Regulations.

32.2 There are a number of Acts of Parliament and Government Regulations which apply to burials and cremations and also to the way cemeteries are to be maintained. The Local Authorities Cemeteries Order 1977 is summarised in Regulation 30. If there is any conflict between any of the above and the Cemetery Regulations, then the above shall apply.

32.3 All Cemetery Regulations previously made are hereby revoked.



St. Helens Council

**Contact Centre**

Wesley House  
Corporation Street  
St. Helens  
WA10 1HF

**Tel:** 01744 676789

**Minicom:** 01744 671671

**Fax:** 01744 676895

**Email:** [contactcentre@sthelens.gov.uk](mailto:contactcentre@sthelens.gov.uk)

→ [www.sthelens.gov.uk](http://www.sthelens.gov.uk)



Please contact us to request translation of Council information into Braille, audio tape or a foreign language.